

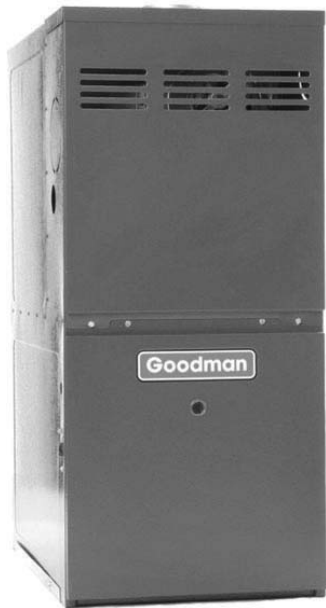

Air Conditioning & Heating



HEATING INPUT:
70,000–115,000 BTU/H

PRODUCT SPECIFICATIONS



GME8 SERIES

80% AFUE

**MULTI-POSITION,
TWO-STAGE (CONVERTIBLE),
MULTI-SPEED GAS FURNACE**



The Goodman® GME8 80% AFUE Two-Stage (Convertible), Multi-Speed Multi-Position Gas Furnace features a patented aluminized-steel tubular heat exchanger and durable Silicon Nitride Hot Surface Ignition system, plus a super-efficient EEM circulator motor that saves energy during the heating and cooling months. With a heavy-gauge, reinforced, insulated steel cabinet and durable baked enamel finish, the GME8 can be installed in a variety of locations.

Standard Features

- Patented TuffTube™ dual-diameter tubular heat exchanger with lifetime limited warranty plus 10-year limited furnace replacement warranty*
- Two-stage gas valve with revolutionary new convertible technology that allows installer to turn on two-stage operation with the flip of a dipswitch
- Super-efficient EEM circulator motor saves energy during heating and cooling months
- Silicon Nitride igniter with patented adaptive learning control for maximum igniter life
- Furnace control board with self-diagnostics, color-coded low-voltage terminals, and provisions for electronic air cleaner and 24-volt humidifiers
- Control board stores the last five diagnostic codes in memory; simple push-button activation outputs the fault history to a flashing red LED
- Low constant fan allows homeowner to activate the low heat speed to efficiently circulate air throughout the home.



- Self-adjusting feature automatically adjusts furnace to high or low stage based on outside temperature without an outdoor temperature sensor
- All models comply with California NOx emissions standards

Cabinet Features

- Fully insulated, heavy-gauge steel cabinet with durable baked-enamel finish
- Foil-faced insulation lines the heat exchanger
- Designed for multi-position installation: upflow, horizontal left or right
- Removable bottom for side- or bottom-return applications
- Convenient left or right connection for gas and electric service
- Coil and furnace fit flush for most installations

* For full warranty details, visit www.goodmanmfg.com.



PRODUCT SPECIFICATIONS

NOMENCLATURE

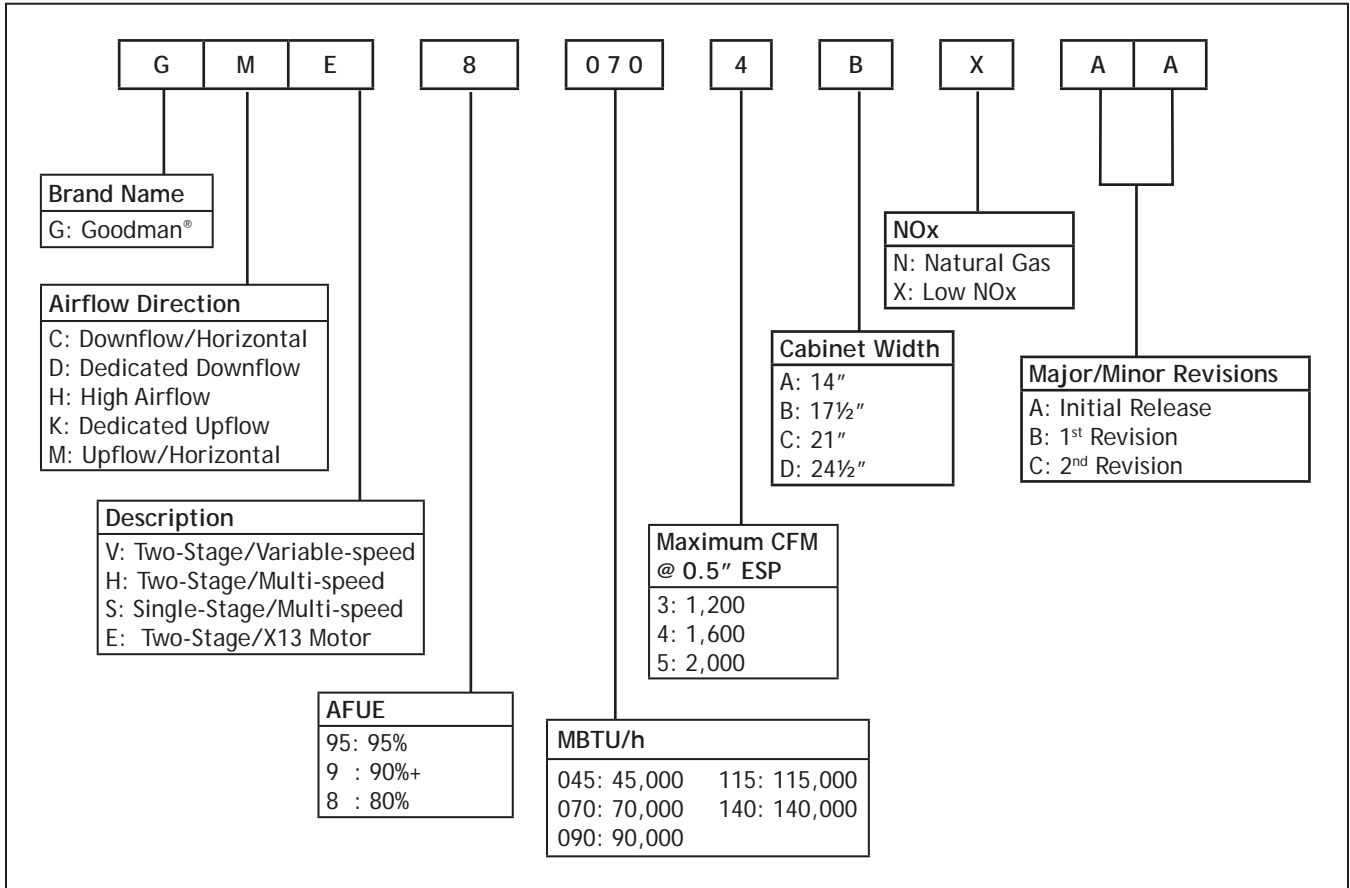

SPECIFICATIONS

	GME80704BXA	GME80905CXA	GME81155CXA
Performance Data			
Input ¹	70,000	90,000	115,000
Natural Gas Output ¹	56,000	72,000	92,000
LP Output ¹	46,000	64,000	80,000
AFUE ²	80%	80%	80%
Tons AC @ 0.5" ESP	4	5	5
Temperature Rise Range (°F)	20-50	35-65	35-65
Circulator Blower			
Size (D x W)	10 X 8	10 X 10	10 X 10
HP	3/4	1	1
Speed	5	5	5
Vent Diameter ³	4	4	4
No. of Burners	3	4	5
Filter Size (in²)⁴			
Disposable	385	480	480
Permanent	770	960	960
Electrical Data			
Min. Circuit Ampacity ⁵	11.9	13.9	13.9
Max. Overcurrent Protection ⁶	15 amps	15 amps	15 amps
Ship Weight (lbs)	143	163	163

¹ Natural Gas BTU/h: for altitudes above 2,000', reduce input rating 4% for each 1,000' above sea level. Low-fire rate is 75% of high-fire rate.

² DOE AFUE based upon Isolated Combustion System (ICS).

³ Vent diameter may vary depending upon vent length. Refer to the latest editions of the National Fuel Gas Code NFPA 54/ANSI Z223.1 (in the USA) and the Canada National Standard of Canada, CAN/CSA B149.1 and CAN/CSA B142.2 (in Canada).

⁴ Permanent filter size based on 600 FPM. Check with filter manufacturer for specific details.

⁵ Minimum Circuit Ampacity = (1.25 x Circulator Blower Amps) + ID Blower amps. Wire size should be determined in accordance with National Electrical Codes. Extensive wire runs will require larger wire sizes.

⁶ Refers to maximum recommended fuse or circuit breaker size; may use fuses or HACR-type circuit breakers of the same size as noted.

Notes:

- All furnaces are manufactured for use on 115 VAC, 60 Hz, single phase electrical supply.
- Gas Service Connection 1/2" FPT
- Important: It is required to size overcurrent protection device and wires properly and make electrical connections in accordance with the National Electrical Code and/or all existing local codes.

PRODUCT SPECIFICATIONS

DIMENSIONS

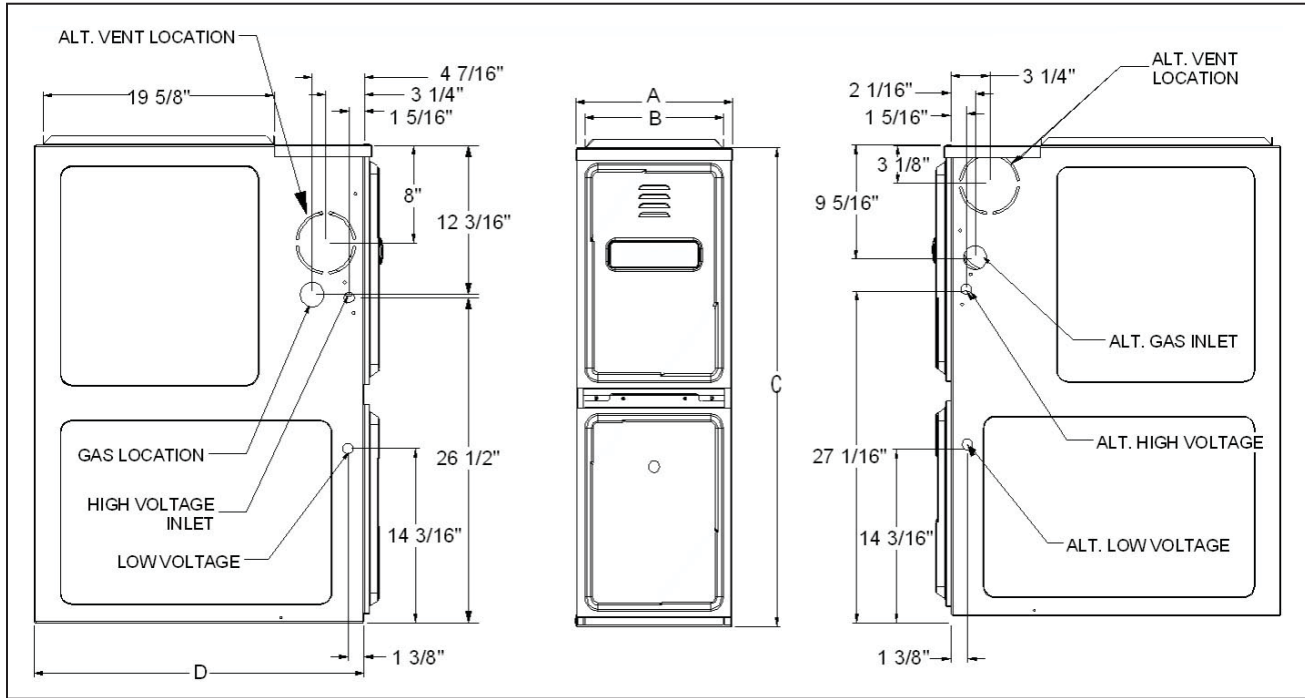

Model	A	B	C	D
GME80704BXA	17 1/2"	16"	39"	28"
GME80905CXA	21"	19 1/2"	39"	28"
GME81155CXA	21"	19 1/2"	39"	28"

MINIMUM CLEARANCES TO COMBUSTIBLE MATERIALS

Sides	Rear	Front	Bottom	Vent		Top
				SW	B	
1	0	3	C	6	1	1

C = If placed on combustible floor, the floor MUST be wood ONLY.

Notes:

- For servicing or cleaning, a 24" front clearance is recommended.
- Unit connections (electrical, flue, and drain) may necessitate greater clearances than the minimum clearances listed above.
- In all cases, accessibility clearance must take precedence over clearances from the enclosure where accessibility clearances are greater.
- Refer to the appropriate USA and Canadian codes:
 - ◊ In the USA: the National Fuel Gas Code NFPA 54 / ANSI Z223.1
 - ◊ In Canada: the Canada National Standard of Canada, CAN/CSA B149.1 and CAN/CSA B142.2

BLOWER PERFORMANCE SPECIFICATIONS

CFM & Temperature Rise vs. External Static Pressure

Model	Motor Speed	Tons AC *	External Static Pressure, (Inches Water Column)												
			0.1		0.2		0.3		0.4		0.5		0.6	0.7	0.8
			CFM	Rise	CFM	Rise	CFM	Rise	CFM	Rise	CFM	Rise	CFM	CFM	CFM
GME8 0704BXA	T1	3.0	1,224	42	1,178	44	1,162	45	1,139	46	1,106	47	1,060	1,029	987
	T2	3.5	1,515	34	1,411	37	1,424	36	1,385	37	1,361	38	1,328	1,300	1,266
	T3	1.5	781	66	642	81	561	92	501	103	425	122	365	326	288
	T4	2.0	863	60	842	62	783	66	741	70	690	75	645	572	532
	T5	2.5	1,083	48	1,044	50	1,012	51	989	52	946	55	904	877	825
GME8 0905CXA	T1	2.5	1,184	56	1,109	60	1,068	62	995	67	898	74	860	808	765
	T2	3.5	1,537	43	1,488	45	1,448	46	1,404	47	1,371	49	1,314	1,247	1,181
	T3	3.0	1,359	49	1,288	52	1,243	54	1,212	55	1,146	58	1,079	1,039	976
	T4	4.0	1,658	40	1,610	41	1,604	42	1,548	43	1,511	44	1,470	1,416	1,365
	T5	5.0	2,185	31	2,081	32	2,004	33	1,948	34	1,924	35	1,806	1,668	1,480
GME8 1155CXA	T1	3.0	1,351	63	1,315	65	1,261	68	1,197	71	1,133	75	1,037	966	909
	T2	4.5	1,777	48	1,692	50	1,640	52	1,627	52	1,578	54	1,517	1,472	1,214
	T3	3.5	1,548	55	1,470	58	1,449	59	1,395	61	1,337	64	1,244	1,166	1,096
	T4	4.0	1,720	50	1,633	52	1,601	53	1,570	54	1,521	56	1,462	1,402	1,201
	T5	5.0	2,312	37	2,213	38	2,155	40	2,099	41	1,988	43	1,864	1,691	1,501

* at 0.5" ESP

Notes:

- CFM in chart is without filter(s). Filters do not ship with this furnace, but must be provided by the installer. If the furnace requires two return filters, this chart assumes both filters are installed.
- For most jobs, about 375 - 400 CFM per ton when cooling is desirable.
- INSTALLATION IS TO BE ADJUSTED TO OBTAIN TEMPERATURE RISE WITHIN THE RANGE SPECIFIED ON THE RATING PLATE.
- This chart is for information only. For satisfactory operation, external static pressure must not exceed value shown on the rating plate. The shaded area indicates ranges in excess of maximum static pressure allowed when heating.
- The above chart is for U.S. furnaces installed at 0-2,000 feet. At higher altitudes, a properly derated unit will have approximately the same temperature rise at a particular CFM, while ESP at the CFM will be lower.
- Factory Motor Speed Setting: T1 = 1st Stage Heating; T2 = 2nd Stage Heating; T5 = Cooling
- Temperature rise data is based on 2nd-stage heat. First-stage heat is 75% of rise indicated above.

BLOWER PERFORMANCE SPECIFICATIONS (CONT.)

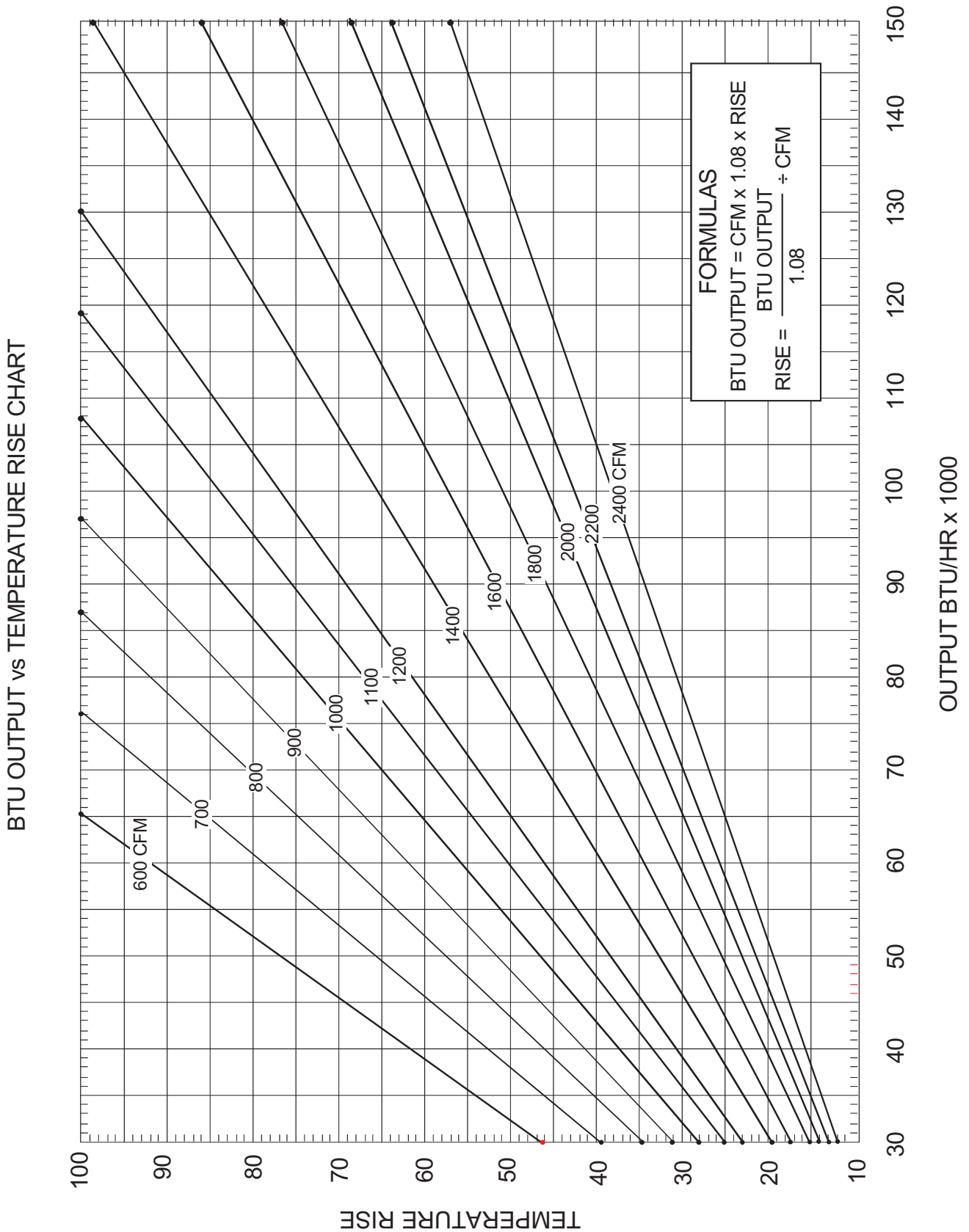

WIRING DIAGRAMS

WARNING
 HIGH VOLTAGE!
 DISCONNECT ALL POWER BEFORE SERVICING OR INSTALLING THIS UNIT. MULTIPLE POWER SOURCES MAY BE PRESENT. FAILURE TO DO SO MAY CAUSE PROPERTY DAMAGE, PERSONAL INJURY OR DEATH.

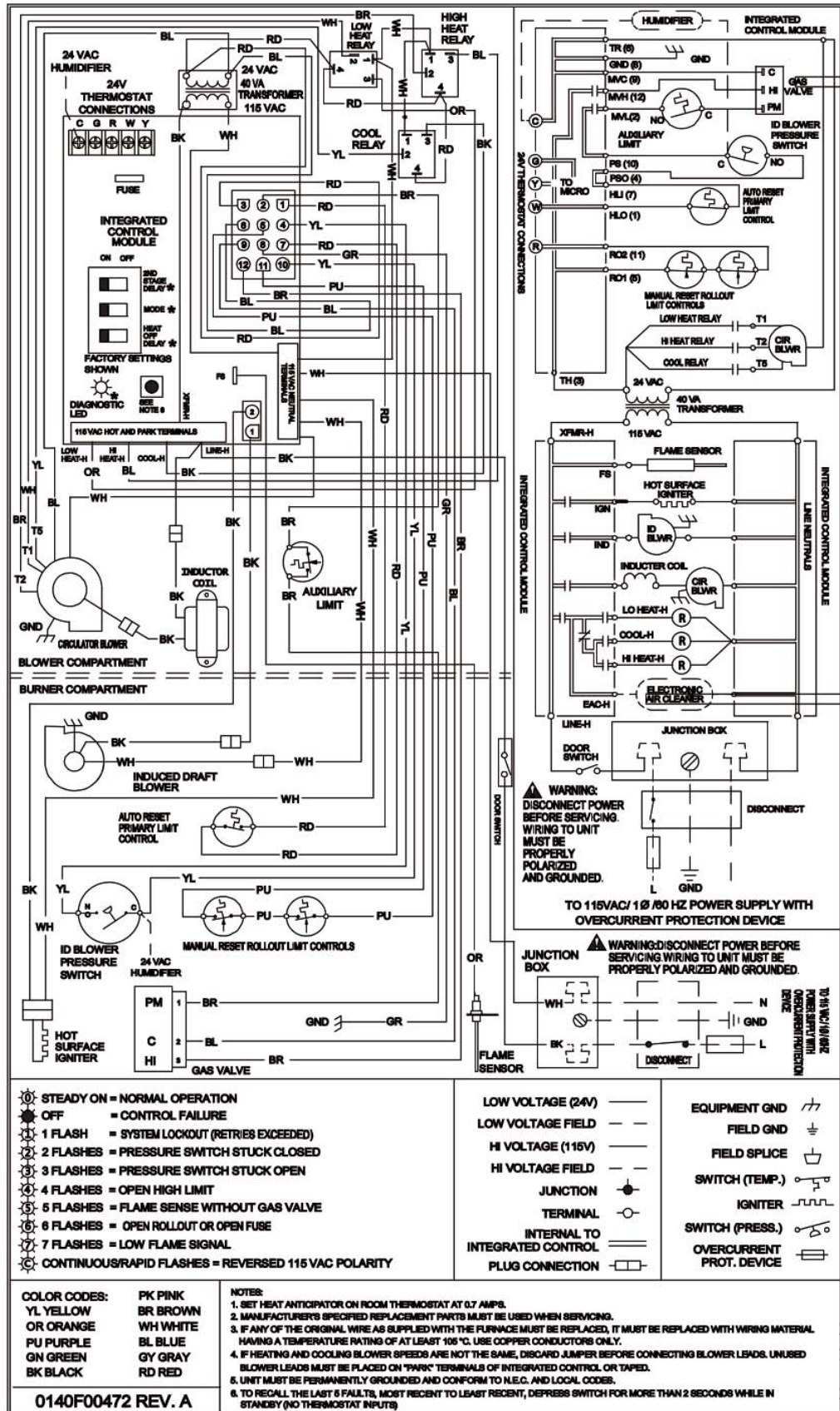

Wiring is subject to change. Always refer to the wiring diagram on the unit for the most up-to-date wiring.

PRODUCT SPECIFICATIONS

DUAL\$AVER CONFIGURATION & OPERATION

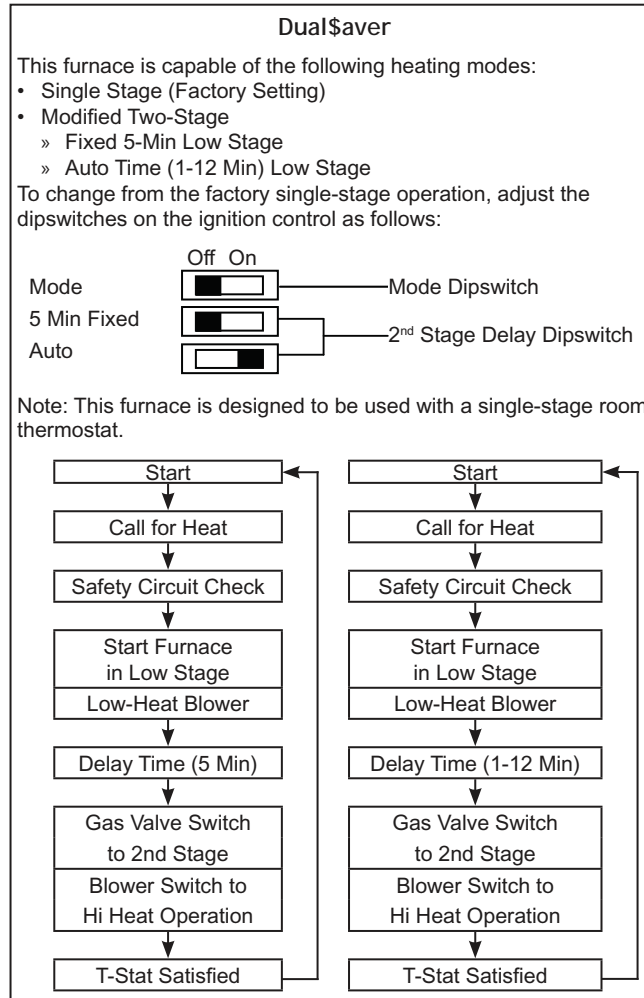

ACCESSORIES

Model	Description	GME8 0704BX	GME8 0905CX	GME8 155CX
LPM-03B	LP Conversion Kit (Gas Valve)	√	√	√
LPM-05	LP Conversion Kit (Springs & Orifice)	√	√	√
HA02	High-Altitude Natural Gas Kit	√	√	√
AFE18-60A	Fossil Fuel Kit	√	√	√

THERMOSTATS

Model	Description
CHT18-60	Cooling/Heating, Mechanical
CH70TG	Cooling/Heating, Digital, Non-programmable
CHSATG	Cooling/Heating, Mechanical
H20TWR	Heating Only, Mechanical



Goodman Manufacturing Company, L.P., reserves the right to discontinue, or change at any time, specifications or designs without notice or without incurring obligations.

Copyright © 2007 • Goodman Manufacturing Company, L.P. • Houston, Texas • Printed in the USA.